

Mixer pump MP 25 MIXIT

The machine with the large reservoir for premixed dry mortar

Easy to disassemble, but difficult to outperform. The reliable MP 25 is a real all-rounder.

Suitable for all pumpable premixed dry mortar, whether it's bag material or from a silo with a conveying system, e.g. interior plasters (gypsum and gypsum lime plaster), external plaster (lime, lime cement, and insulating plaster), self levelling floor screed, cementitious adhesive, and reinforcement mortar. Different pump parts and pump versions can vary the mix and pump output from around 5 to 80 l/min.



Powerful electric motor

Reservoir hopper takes 115 l

MP 25 can be dismantled into manageable assemblies

Conical mixing tube for optimum material flow

Easily accessible flow meter for modifying the water ratio

Compressed air remote control

Integrated water pump

Integrated compressor with pressure cut-off



Technical data	MP 25 MIXIT – 3 x 400 V 50 HZ	MP 25 MIXIT – 3 x 220 V 60 HZ
Pump	D6 Power	D6 Power
Theor. delivery rate*	25 l/min	25 l/min
Delivery pressure	40 bar	25 bar
Delivery distance**	Up to 40 m horizontal, 15 m vertical	Up to 40 horizontal, 15 m vertical
Air compressor	0.55 kW / 200 l/min	–
Pump drive	400 V / 50 Hz / 5.5 kW at 392 rpm	220 V / 60 Hz / 5.5 kW at 392 rpm
Container drive	1.1 kW at 23 rpm	1.1 kW at 23 rpm
Container content	115 l	115 l
Water pump	0.78 kW at 3.4 m³/h	0.78 kW at 3.4 m³/h
Weight	240 kg	245 kg
Length x width x height	1,324 x 728 x 1,443 mm	1,324 x 728 x 1,443 mm
Filling height	984 mm	984 mm
Maximum particle size	4 mm	4 mm
Pressure connections	M35/V25-40	M35/V25-40
Part no.	111 417.168	111 417.155

* The delivery rate depends on the pump model. The delivery rate can vary in accordance with the pump used.

**The data is based on experience and is dependent on the materials used.



The large hopper and the low fill level make it distinctively more convenient and make your work easier.



The material container and mixing tube are separated from each other. You open the gate valve and the material enters the mixing tube.



The MP 25 MIXIT can be dismantled into manageable and, more importantly, portable assemblies in no time at all.

Equipment	MP 25 MIXIT – 400 V	MP 25 MIXIT – 220 V
Standard colour paintwork	●	●
Water pump	●	●
Compressor	●	●
Suction hose for water pump	○	○
Cable remote control + extension	○	○
Uni remixer	○	○
Insulating plaster attachment	○	○
Air injection hood	○	○
Spacer plates	○	○
Key:	– Not available ○ Option ● Standard	

Suggested accessories for MP 25

Accessories for processing premixed dry mortar (impressive output of 40 l/min)

Entire set, part no.: 533 072
 ≈ 30 m long, consisting of:

	Part	Part no.	Fig.
1x	Pump parts – Screw conveyor D8-2 – Screw conveyor barrel D8-2	435 743 436 746	1
1x	Universal mixer shaft MP 25	211 773.003	2
1x	Spray gun, short and straight, V 35	203 054.002	3
2x	Mortar hose ID 35, 13.3 m long	207 615.007	4
2x	Air hose, 1/2", 20 m	001 665.004	5
10x	Sponge ball ID 35	065 044.001	6
10x	Seal ID 35	213 725.004	7
3x	Hose holder, leather	000 206.008	

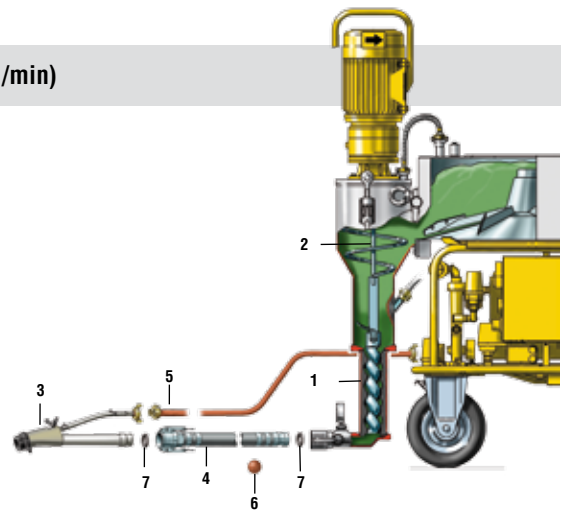

Accessories for the processing of premixed dry mortar from a silo

Entire set, part no.: 533 078
 ≈ 30 m long, consisting of:

	Part	Part no.	Fig.
2x	Mortar hose ID 35, 13.3 m long	207 615.007	1
2x	Air hose, 1/2", 20 m	001 665.004	2
10x	Seal ID 35	213 725.004	3
10x	Sponge ball ID 35	065 044.001	4
1x	Spray gun, short and straight V 35	203 054.002	5
1x	Feed hood with remote control cable Probe, rectangular	212 324.008	6
3x	Hose holder, leather	000 206.008	

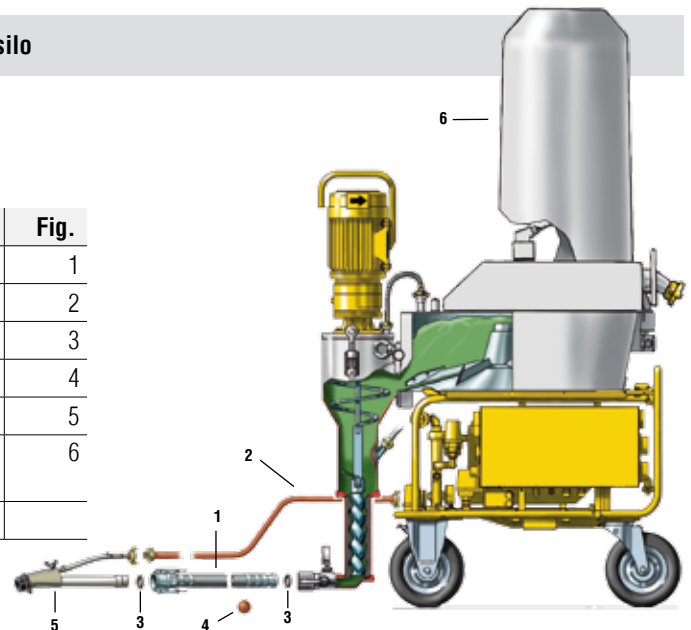

Accessories for processing premixed dry mortar

Entire set, part no.: 533 079
 ≈ 20 m long, consisting of:

	Part	Part no.	Fig.
2x	Mortar hose ID 25-40, 10 m long	207 804.009	1
1x	Spray gun ID 25	402 592	2
5x	Seal ID 25	207 764.000	3
5x	Sponge ball ID 30	000 239.004	4
3x	Hose holder, leather	000 206.008	

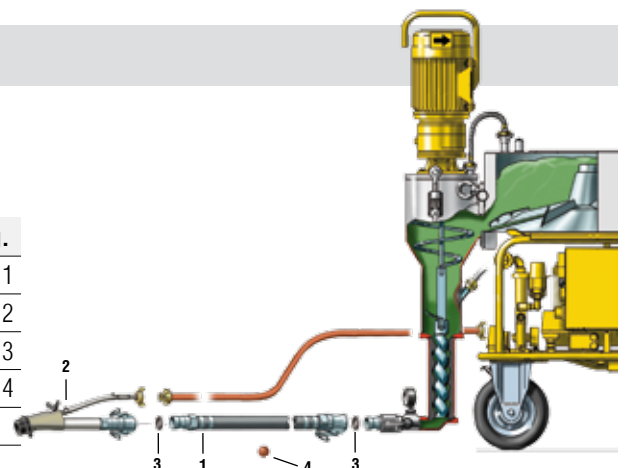

Accessories for processing insulating plaster (impressive output of 40 l/min)

Entire set, part no.: 533 074
≈ 40 m long, consisting of:

	Part	Part no.	Fig.
1x	Pump parts – Screw conveyor D8-2 – Screw conveyor barrel D8-2	435 743 436 746	1
1x	Mixer shaft for insulating plaster MP 25	212 262.005	2
1x	Spray gun, with shut-off valve ID 35	209 174.009	3
3x	Mortar hose ID 35, 13.3 m long	207 615.007	8
2x	Air hose, 1/2", 20 m	001 665.004	4
10x	Sponge ball ID 35	065 044.001	6
10x	Seal ID 35	213 725.004	5
3x	Hose holder, leather	000 206.008	
1x	Attachment collar for insulating plaster MP 25	212 325 007	7

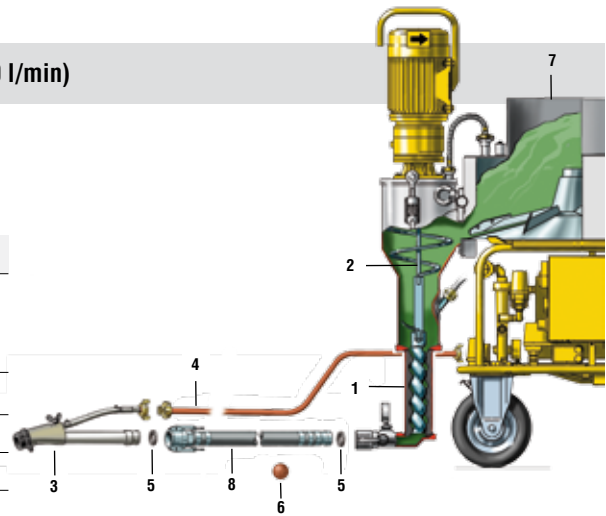

Accessories for processing cementitious adhesive, reinforcement mortar, and structural plaster (low output of 12 or 6 l/min)

Entire set, part no.: 533 073
≈ 20 m long, consisting of:

	Part	Part no.	Fig.
1x	Pump parts – Screw conveyor D4-1/2 – Screw conveyor barrel D4-1/2	214 402.009 214 403.008	1
1x	Cementitious adhesive mixer shaft	214 571.008	2
1x	Flow meter with range of 40 - 400 l/min	208 025.007	3
1x	Insertion nozzle, diameter of 4.5 x 55 mm	400 728	4
2x	Mortar hose ID 25-40, 10 m long	207 804.009	5
1x	Large fine plaster spray gun with PM coupling and Geka air connection	529 733	8
1x	Air hose, 1/2", 20 m	001 665.004	11
5x	Sponge ball ID 25	000 239.004	9
5x	Seal ID 25	207 764.000	10
3x	Hose holder, leather	000 206.008	

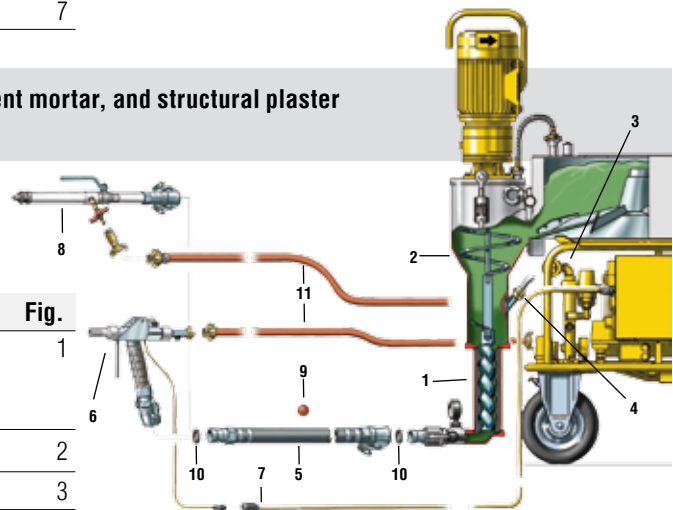

	Part	Part no.	Fig.
1x	Flow meter with range of 40 - 400 l/min	407 200	3
1x	Adhesive gun ID 17/ M 25-40 with shut-off valve and E-connector for remote control	408 422	6
1x	Extension cable 20 m	211 506.005	7

